

This document must not be copied without our written permission, and the contents thereof must not be imparted to a third party nor be used for any unauthorized purpose. Contravention will be prosecuted.

Den här ritning är vår egendom och skyddad enligt gällande lag samt får ej utan vårt medgivande kopieras, delgivas annan eller obehörigen användas.

ISO-Toleranser  
ISO-Tolerances

Ytjämnhet Ra/  
Surface  
roughness Ra

För ej tolerans-  
satta mått  
gäller för meas-  
urements without  
tolerances  
applies  
SS-ISO 2768-01m

Basmått (mm)	Tol (mm)
- 6	±0.1
6.1- 30	±0.2
30- 120	±0.3
120- 400	±0.5
400- 1000	±0.8



Base valve piston (Compression)

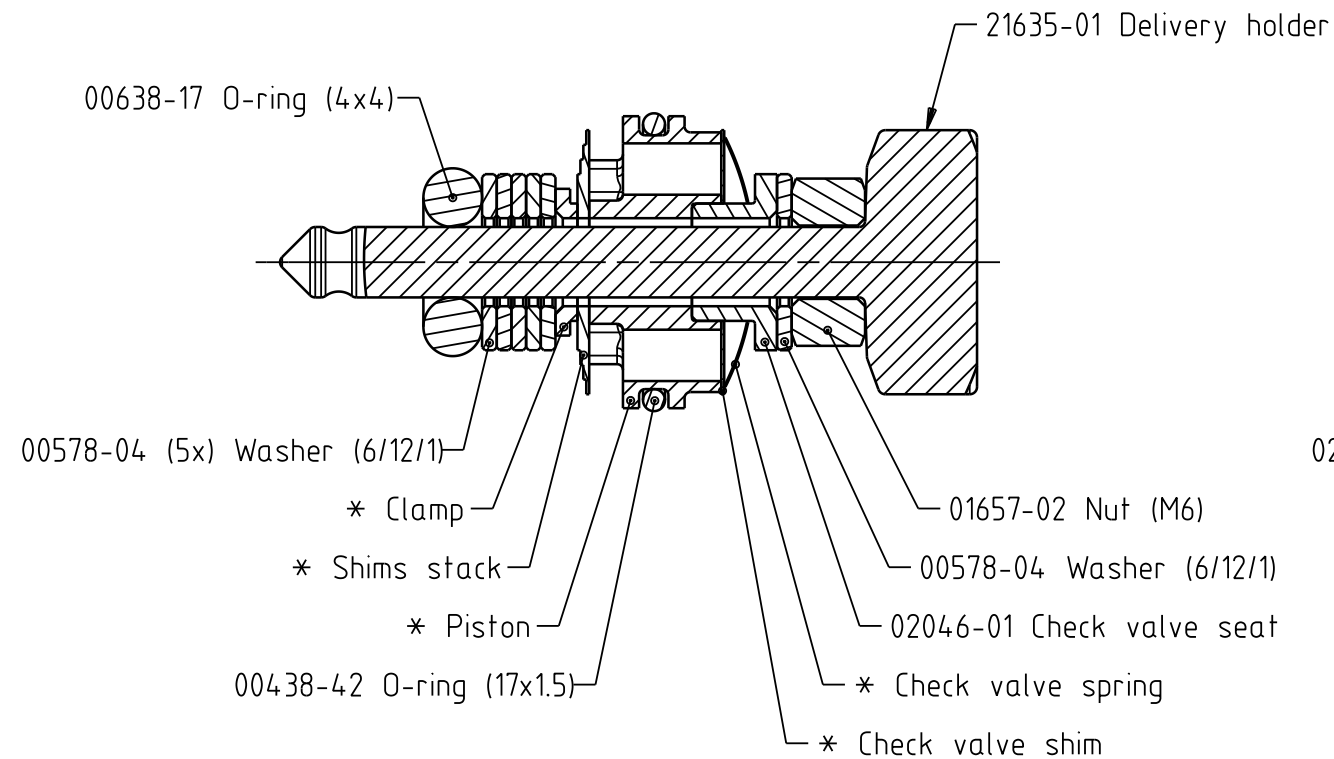

Main piston (Rebound)

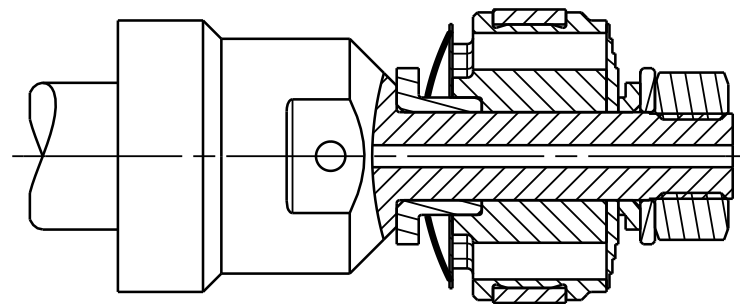
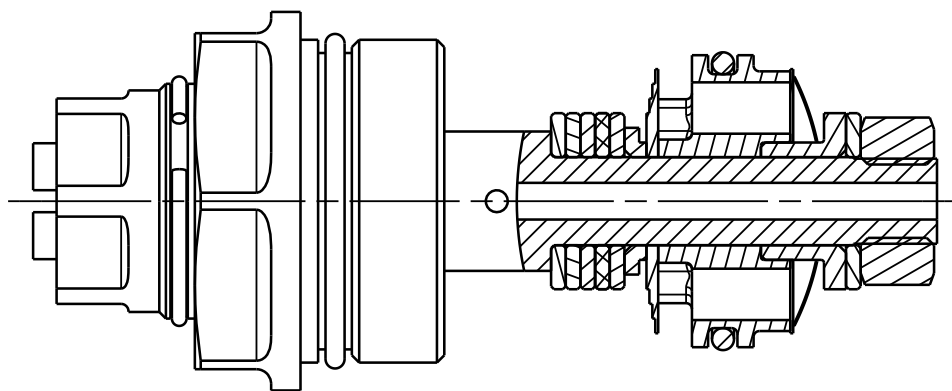
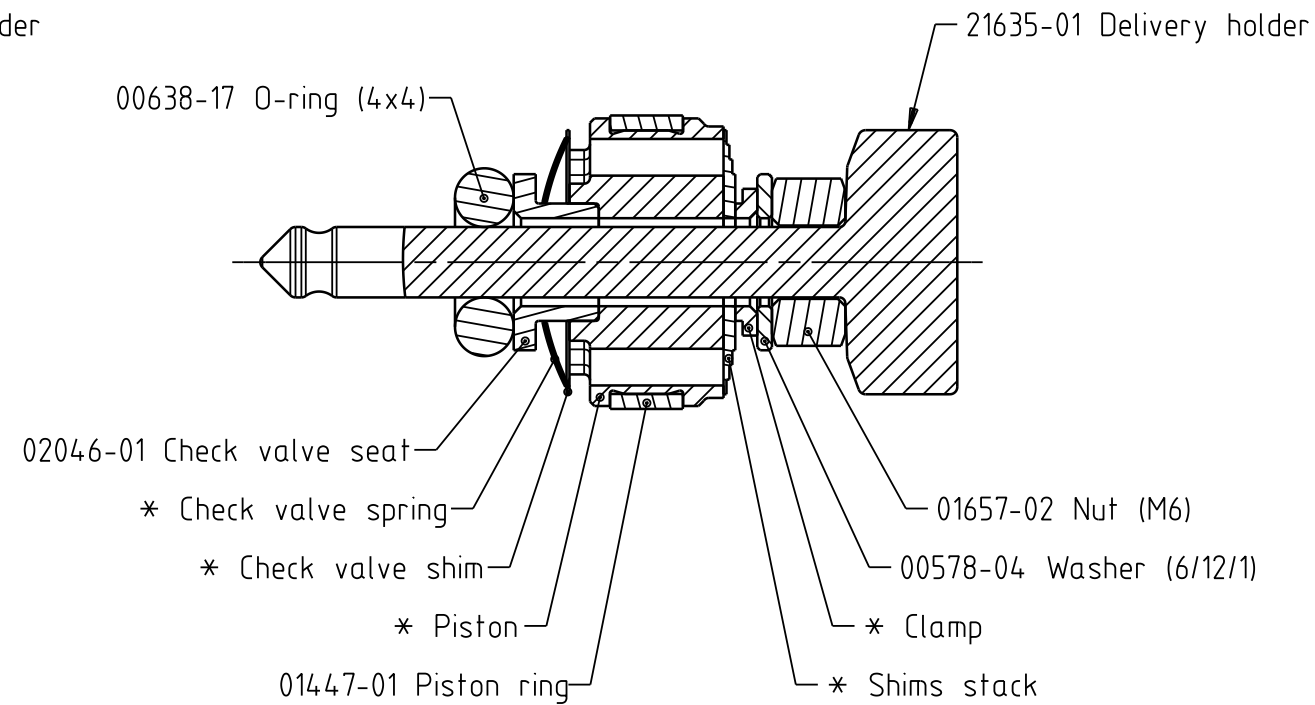

\* See spec card

Rev.	Ändringens art/Type of change	Sign.	Datum/Date	Äm./Rev. nr

Material		Värmebehandling/Heat treatment		Ytbehandling/Surface treatment	
Datum/Date	Ritad/Drawn	Godkänd/Approved	Format-Skala/Scale	Lösa grader för ej förekomma / No loose burrs allowed	Jämför/Compare
2008-05-30	DN	LJL	A3 2:1		03200-01
Benämning/Designation			Ritning nr/Drawing number		Revison
			Front fork piston kit Suzuki GSX-R1000		FPK_104