

Before installing this product, check the contents of the kit. If anything is missing, please contact your Öhlins dealer.

Kit Contents	Pcs
Compression Piston Assembly	2
Rebound Piston Assembly	2
Öhlins Sticker (60x23) white 00191-32	2
Öhlins Sticker (60x23) blue 00191-33	2

**Warning!**

This kit should only be installed by an authorized Öhlins Centre. The installation procedure requires special Öhlins tools.

Öhlins products are subject to continuous improvement and development, therefore, although these instructions include the most up-to-date information available at the time of printing, minor updates may occur.

To find the latest information, please contact your Öhlins distributor. Please consult your Öhlins dealer if you have any questions regarding the contents in this document.

Part no. FPK 105\_1  
Issued 2009-03-24



## Front Fork Piston Kit for Kawasaki ZX-10R

# FPK 105

### Mounting Instructions

© Öhlins Racing AB. All rights reserved.  
Any reprinting or unauthorized use without the written permission of Öhlins Racing AB is prohibited.

Öhlins Racing AB  
Box 722  
S-194 27 Upplands Väsby, Sweden  
Phone +46 8 590 025 00  
fax +46 8 590 025 80



[www.ohlins.com](http://www.ohlins.com)



## Note!

The front fork is a very important part of the vehicle and will therefore affect the stability of the vehicle.

Read and make sure that you understand the information in this manual before you use this product. If you have any questions regarding installation or maintenance please contact your nearest Öhlins dealer.

Öhlins Racing AB can not be held responsible for any damage to the front fork, vehicle, other property or injury to persons, if the instructions for installing and maintenance are not followed exactly.

## Warning!

This product was developed and designed exclusively for a specific vehicle model and should only be installed on the intended vehicle model in its original condition as delivered from the vehicle manufacturer.

After installing this product, take a test ride at low speed to make sure that your vehicle has maintained its stability.

## Note!

When working on this product, always consult your Vehicle Service Manual.

This Manual should be considered as a part of the product and should therefore accompany the product throughout its life cycle.

## Safety Symbols

In this manual, mounting instructions and other technical documents, important information concerning safety is distinguished by the following symbols:



The Safety Alert Symbol means: Warning! Your safety is involved.

## Warning!

The Warning Symbol means: Failure to follow warning instructions can result in severe or fatal injury to anyone working with, inspecting or using the front fork, or to bystanders.

## Caution!

The Caution Symbol means: Special precautions must be taken to avoid damage to the front fork.

## Note!

The Note Symbol indicates information that is important regarding procedures.

© Öhlins Racing AB. All rights reserved. Any reprinting or unauthorized use without the written permission of Öhlins Racing AB is prohibited. Printed in Sweden.

Base Valve Piston - Compression

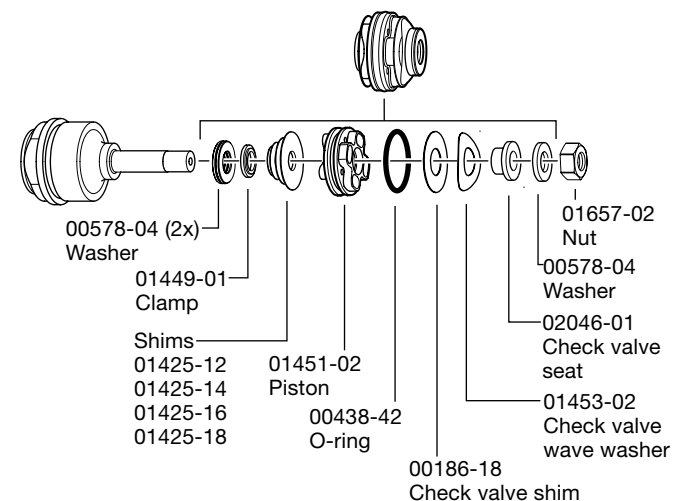

Main Piston - Rebound

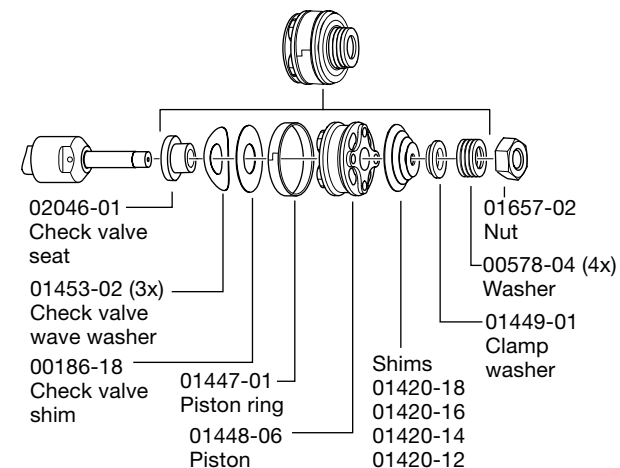

### Recommended set-up

Compression	5 clicks
Rebound	8 clicks
Spring Preload	7 rings
Oil Level	110 mm

### Optional Springs

Part No.	Rate
08759-95	9.5 N/mm
08759-10	10.0 N/mm
Standard Rate	9.4 N/mm

### Recommended Öhlins Tools

Clamping tool Ø10/12	00727-02
Clamping tool Ø24	00787-01
Preload tube pusher tool	01766-02

### Lubricants

Öhlins Front Fork Fluid	01309-01
Öhlins Red Grease	00146-01

### Adhesives

- Loctite 243
- Loctite 542
- Loctite 2701

### Recommended OEM Tools

- Seal Head tool
- Pull-up tool
- Stopper Plate Tool

### Recommended Tools

- Impact wrench
- Heat gun
- Allen key
- Open Wrench
- File
- Vice

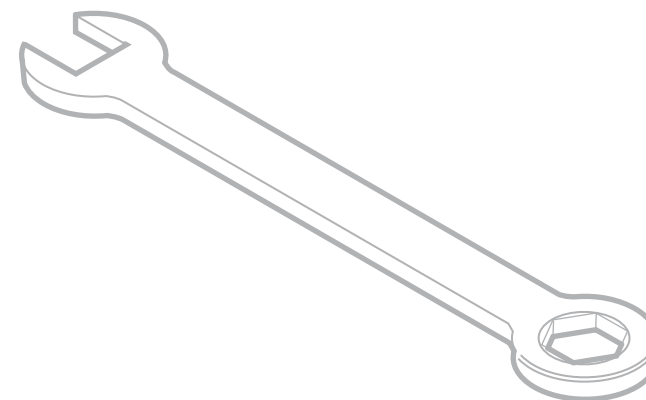

# How to install

## 1. Remove the Front Fork

### ⚠ Warning!

It is advisable to have an Öhlins dealer install the Fork Piston Kit.

When installing, consult your Vehicle Service Manual.

### 1.1

Put the motorcycle on a workstand so that the front wheel barely touches the ground.

### ⚠ Warning!

Make sure the vehicle is securely supported so that it will not tip.

### 1.2

Remove the front fender, brake calipers and the front wheel.

### 1.3

Measure the distance from the top of the outer fork leg to the top of the upper fork crown.

### 👁 Note!

Note the distance. The upper fork crown should be reinstalled at the same position.

### 1.4

Release the spring preload and count the number of turns.

### 👁 Note!

Note the number of turns.

### 1.5

Loosen the upper fork crown by loosening the screws.

### 1.6

Loosen, but do not remove, the top cap half a turn.

### 1.7

Loosen the lower fork crown by loosening the screws.

### 1.8

Remove the fork legs from the fork crowns.

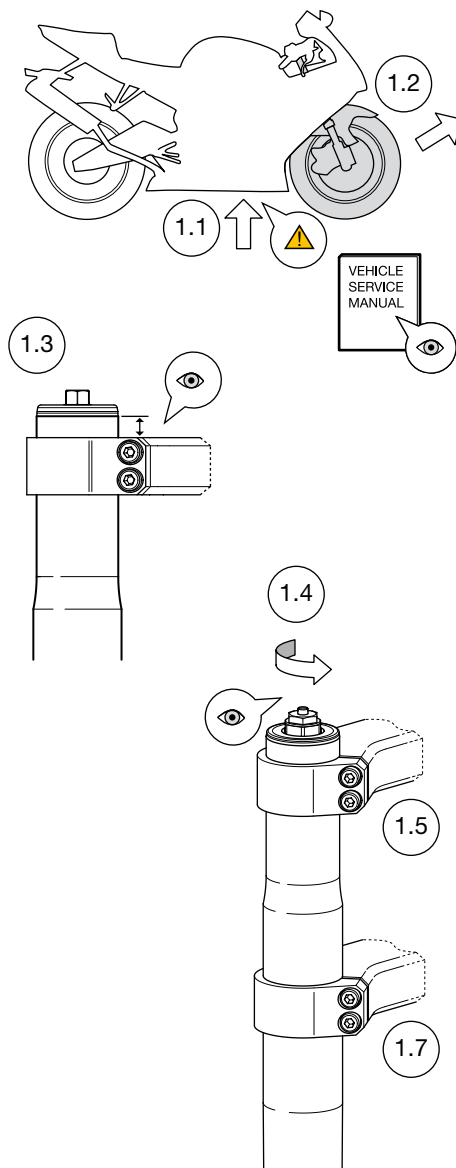

# How to install

## 5.8

Use tool 01766-02, push down the preload tube. Pull up the shaft, use an OEM Pull up Tool. Insert a Stopper plate tool. Assemble the top cap to the shaft by tightening it to the lock nut. Tightening torque: 15 Nm.

### 👁 Note!

Make sure that the distance between the shaft lock nut and the top of the shaft does not change when assembling the top cap.

## 5.9

Assemble the top cap to the outer fork leg. Tightening torque: 10 Nm. Put some grease on the thread and the o-ring. Make sure that the Front Fork is fully extended when tightening the top cap.

## 6 Install the Front Fork

### 6.1

Install the front fork legs into the fork crowns. Tightening torque upper fork crown: 20 Nm  
Tightening torque lower fork crown: 10 Nm

### 👁 Note!

Make sure that the distance between the top of the fork leg and the upper fork crown is the same as measured in chapter 1.3.

### 6.2

Reinstall the front fender, brake calipers and the front wheel. Do not tighten yet.

### 6.3

Put the motorcycle on the ground, apply the front brake and compress the front fork 3-4 times. This will put the legs in an exact parallel position.

### 6.4

Tighten the front wheel, brake calipers and the front fender. Consult your Vehicle Service Manual for correct tightening torques.

### 👁 Note!

Make sure that nothing restricts the fork movement when fully compressed.

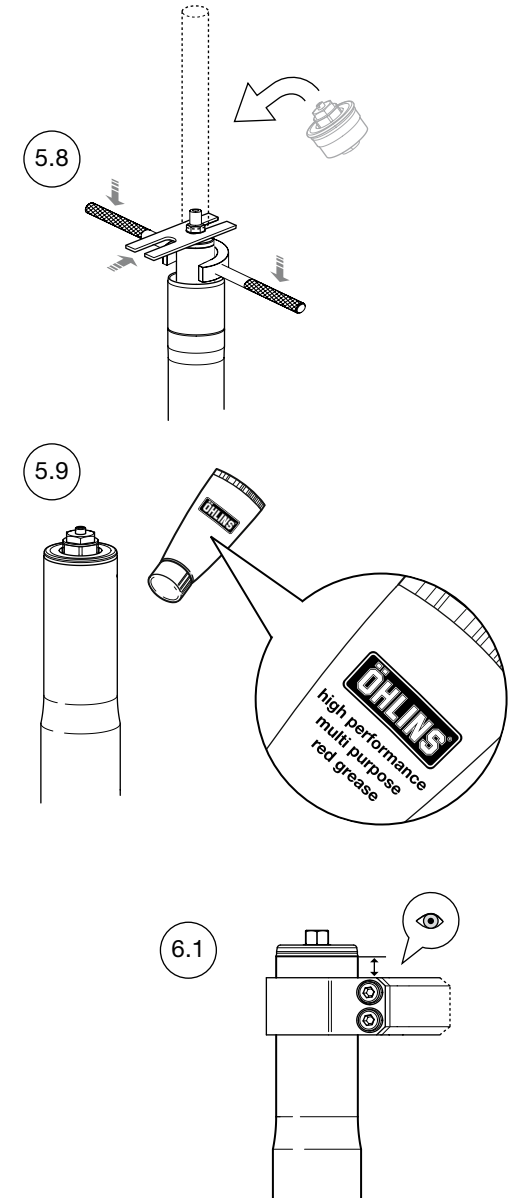

# How to install

## 5 Install the Cartridge Assembly into the Fork Leg

### 5.1

Install the cartridge assembly into the fork leg and tighten the bottom screw.

Tightening torque: 20 Nm. Loctite 243

### 👁 Note!

Check the condition of the copper washer.  
Replace if worn or deformed.

### 5.2

Pour approximately 0,5 litre Öhlins Front Fork fluid into the fork leg.

### 5.3

Install the top cap directly to the shaft, no spring or preload tube. Pull up the outer fork leg and screw it to the top cap. Handtighten only. Pump out all air from the damping system by pulling the outer fork leg up and down 10-15 times.

### 5.4

Remove the top cap.

### 5.5

Make sure that the shaft is in the bottom of the cartridge and the outer fork leg is in its bottom position. Measure the distance from the top of the outer fork leg to the oil surface. Recommended oil level according to Set-up Data in this folder.

### 5.6

Set the distance between the shaft lock nut and the top of the shaft.

### 👁 Note!

Use the same distance between the lock nut and the top of the shaft as in chapter 2.3

### 5.7

Drop the spring and preload tube on top of the cartridge.

### 👁 Note!

Parts in the same order as in chapter 2.5

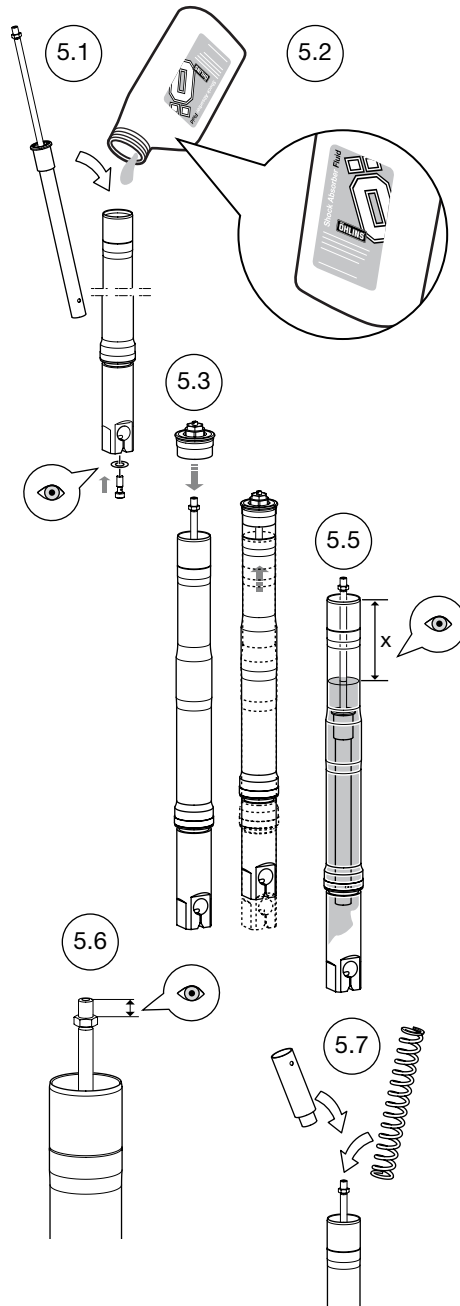

# How to install

## 2 Remove cartridge from fork leg

### 2.1

Loosen the top cap from the outer fork leg and slide the outer fork leg all the way down.

### 2.2

Use tool 01766-02 and push the preload tube down to expose the lock nut. Insert a Stopper Plate Tool below the lock nut.

### 2.3

Loosen the top cap from the shaft.

### 2.4

Measure the distance between the lock nut and the top of the shaft.

### 👁 Note!

Note the distance between the lock nut and the top of the shaft.

### 2.5

Remove the preload tube and the spring.

### 👁 Note!

Note the order between the parts and the direction of the spring.

### 2.6

Turn the fork leg upside down and pour out the oil.

### 2.7

Remove the cartridge assembly by loosening the bottom screw.

### 👁 Note!

Use an impact wrench when loosening the bottom screw.

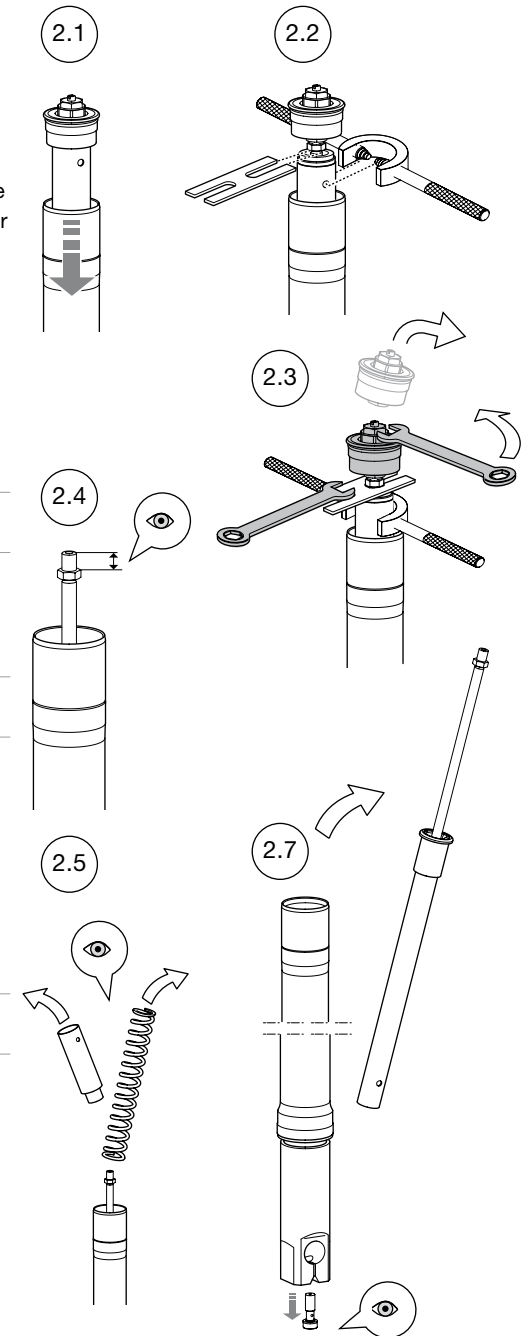

# How to install

## 3 Replace Base Valve Piston (Compression)

### 3.1

Remove the base valve assembly by loosening it from the cylinder tube.

### Note!

We recommend you to use a heat gun to release the Loctite between the base valve and the cylinder tube.

### 3.2

Remove the standard piston and the shims from the base valve by loosening the base valve nut.

### 3.3

Remove the o-ring from the Öhlins piston kit delivery holder.

### 3.4

Slide all components on the delivery holder directly on the base valve. Tighten the base valve nut. Tightening torque 5 Nm. Loctite 243.

### Note!

The o-ring and delivery holder are only delivery parts and shall not be assembled.

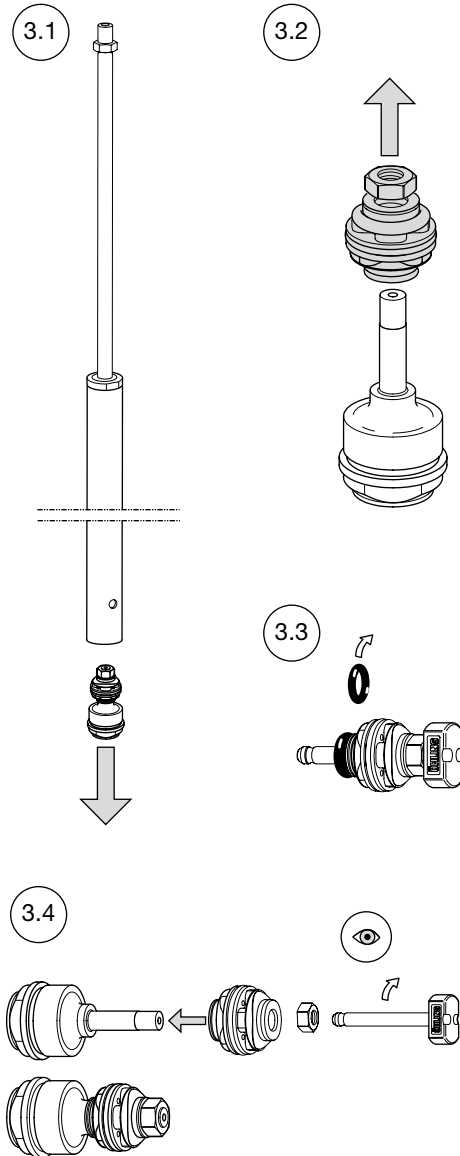

## 4 Replace Main Piston (Rebound)

### 4.1

Remove the shaft lock nut by loosening it from the shaft.

### 4.2

Remove the shaft assembly by sliding it through the seal head.

### 4.3

Remove the standard piston and shims from the piston holder by loosening the piston holder nut.

### Caution!

To remove the nut, remove the deformed thread at the end of the piston holder by grinding. Otherwise you could damage the piston holder.

### 4.4

Remove the o-ring from the Öhlins piston kit delivery holder.

### Note!

The o-ring and the delivery holder are only delivery parts and shall not be assembled.

### 4.5

Slide all components on the delivery holder directly on the piston holder and tighten the piston holder nut. Tightening torque: 5 Nm. Loctite 243.

### 4.6

Slide the shaft assembly back into the cylinder tube and reassemble the shaft lock nut.

### Note!

Do not tighten the lock nut to the end of the thread.

### 4.7

Reinstall the base valve assembly in the cylinder tube. Use red grease on the o-ring. Tightening torque: 40 Nm. Loctite 2701.

