

Kompression / Compression

Retur / Rebound

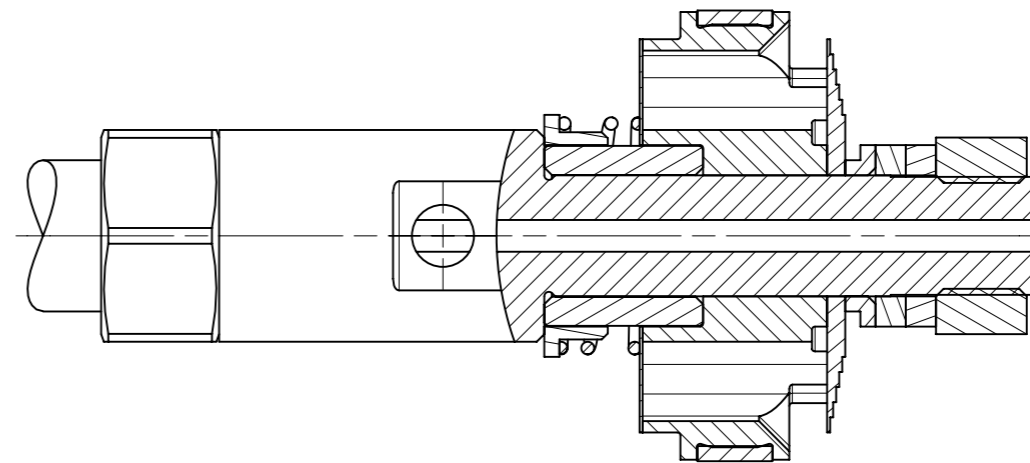
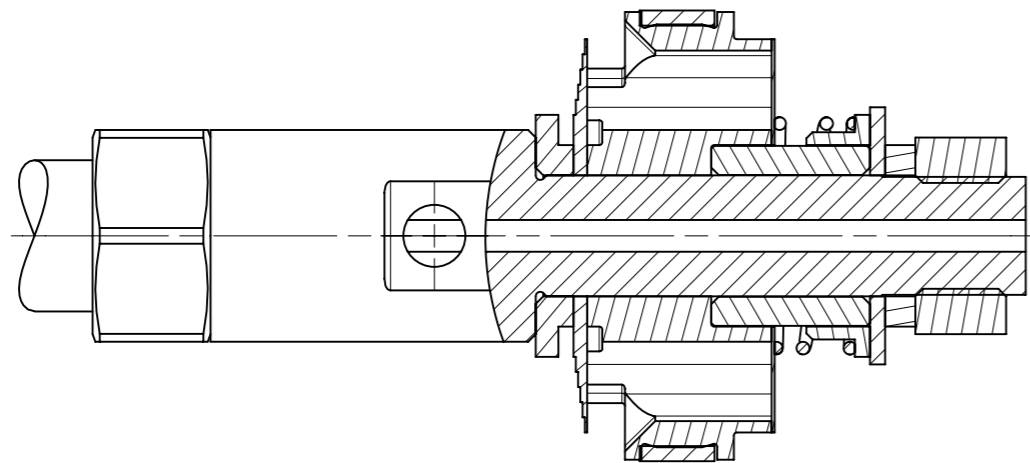
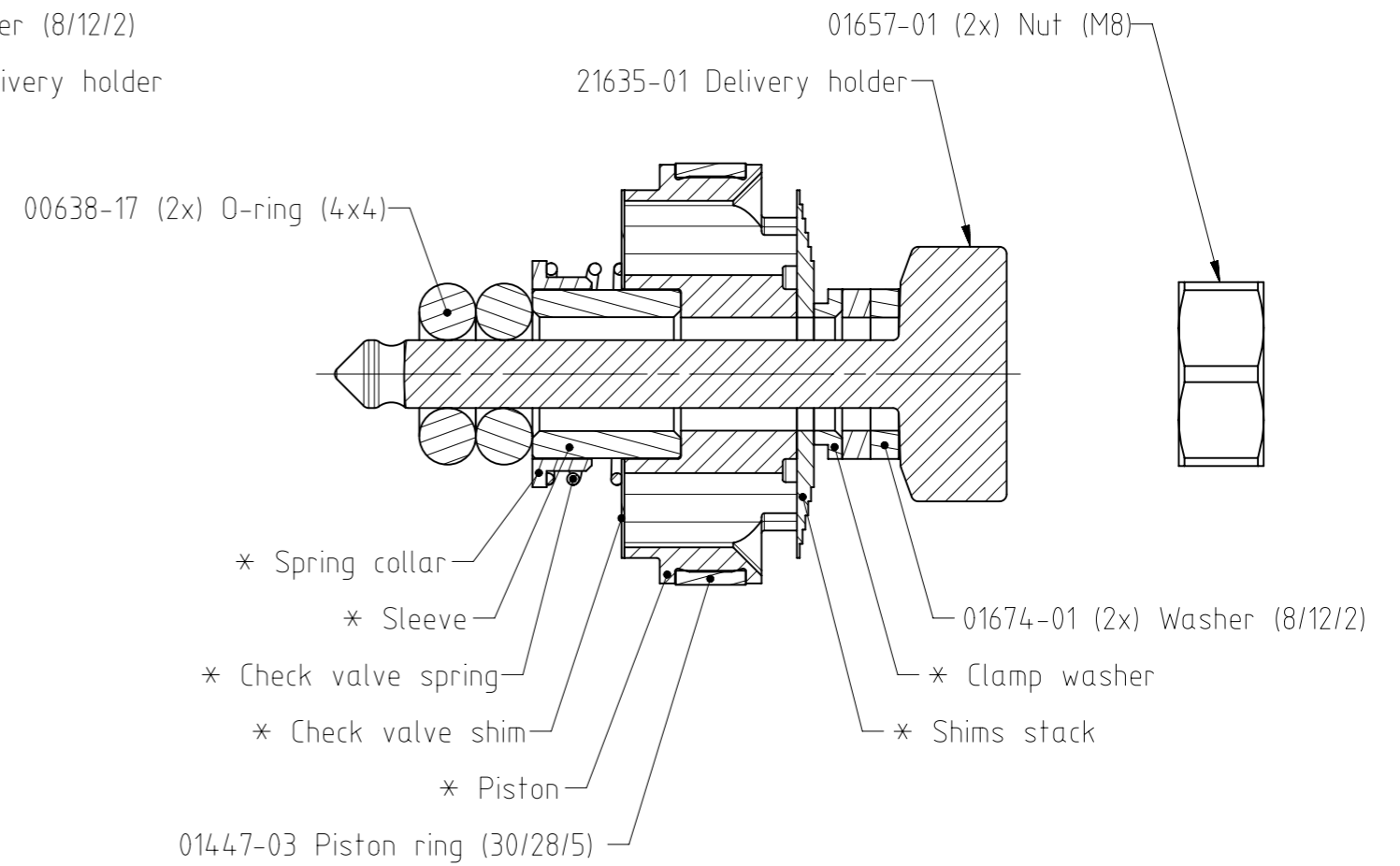
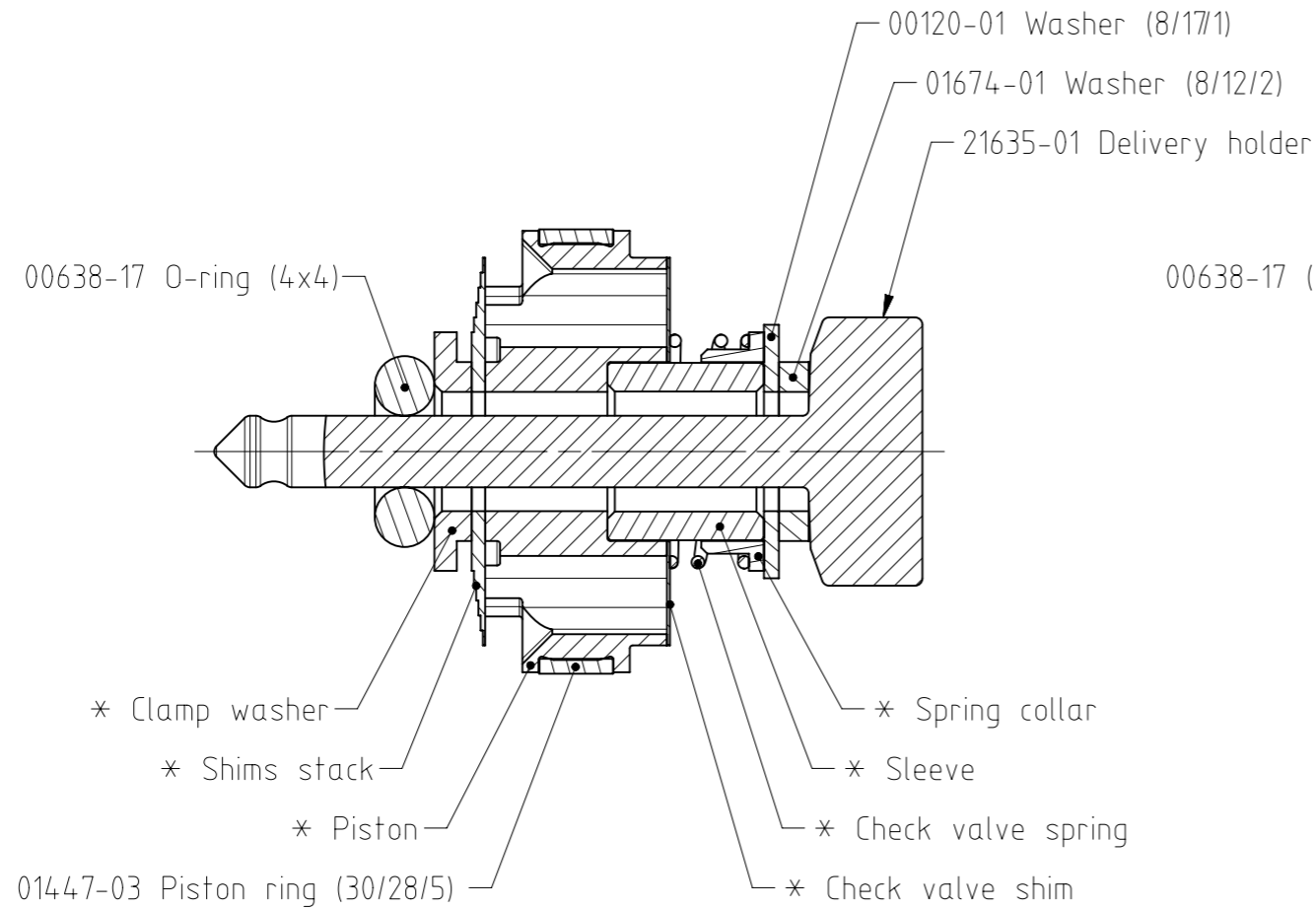

* See spec card

This document must not be copied without our written permission, and the contents thereof must not be imparted to a third party nor be used for any unauthorized purpose. Contravention will be prosecuted.

Denna ritning är vår egendom och skyddad enligt oöflande lag samt får ej utan vårt medgivande kopieras, delgivas annan eller obehörigen användas.

ISO-Toleranser
ISO-Tolerances

Ytjämnhet Ra/
Surface
roughness Ra

För ej tolerans-
satta mått
gäller för meas-
urements without
tolerances
applies
SS-ISO 2768-01m

Basmått (mm)	Tol. (mm)
- 6	±0.1
(6)- 30	±0.2
(30)- 120	±0.3
(120)- 400	±0.5
(400)-1000	±0.8

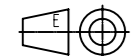

A	Settingkomponenter ändrade	DN	101125	
Rev.	Ändringens art/Type of change	Sign.	Datum/Date	Äm./Rev. nr

Material		Värmebehandling/Heat treatment		Ytbehandling/Surface treatment	
Datum/Date	Ritad/Drawn	Godkänd/Approved	Format-Skala/Scale	Lösa grader för ej förekomma / No loose burrs allowed	Jämför/Compare
2009-01-09	DN	LJL	A3 2:1	-	-
Benämning/Designation				Ritning nr/Drawing number	
Yamaha R1				FPK_108	
				Revision	
				A	