

Shock absorber S46DR1S BMW R 1200RT K5

BM 4381

Spare Parts List



SAFETY PRECAUTIONS

⚠ Warning!

The shock absorber/front fork/steering damper is an important part of the vehicle and will affect the stability.

⚠ Warning!

After installing the Öhlins product, take a test ride at low speed to make sure your vehicle has maintained stability.

⚠ Warning!

Some of Öhlins products contain pressurized nitrogen gas (N₂). Do not open, service or modify pressurized products without proper education (approved Öhlins dealer/distributor) and proper tools.

👁 Note!

Read and ensure you understand the information in this manual and other technical documents provided by Öhlins, before you use the product.

👁 Note!

Öhlins Racing AB can not be held responsible for any damage to the shock absorber/front fork/steering damper, vehicle, other property or injury to persons, if the instructions for mounting, usage and maintenance are not obeyed.

⚠ Warning!

If the suspension makes an abnormal noise, or the function is irregular, or if you notice any leakage from the product, stop the vehicle immediately and return the product to an Öhlins Service Centre.

⚠ Warning!

The product warranty shall only apply if the product has been operated and maintained in accordance with recommendations in this manual. If you have any questions regarding usage, service, inspection and/or maintenance contact Öhlins.

👁 Note!

When working with the Öhlins product, read the Vehicle Service Manual.

⚠ Warning!

This product was developed and designed exclusively for a specific vehicle model and shall only be installed on the intended vehicle model in its original condition as delivered from the vehicle manufacturer.

Contents

Figure 1 - Shock absorber body	3
Figure 2 - Shaft assembly	4
Figure 3 - Cylinder head	5
Figure 4 - Hydraulic adjuster type 1	6

SAFETY SYMBOLS

In this manual, mounting instructions and other technical documents, important information concerning safety is distinguished by the following symbols:



The Safety Alert Symbol means: Warning! Your safety is involved.

⚠ Warning!

The Warning Symbol means: Failure to follow warning instructions can result in severe or fatal injury to anyone working with, inspecting or using the shock absorber, or to bystanders.

👁 Caution!

The Caution Symbol means: Special precautions must be taken to avoid damage to the shock absorber.

👁 Note!

The Note Symbol indicates information that is important regarding procedures.

© Öhlins Racing AB. All rights reserved.

Any reprinting or unauthorized use without the written permission of Öhlins Racing AB is prohibited.

SPL BM 4381

Figure 1 - Shock absorber body

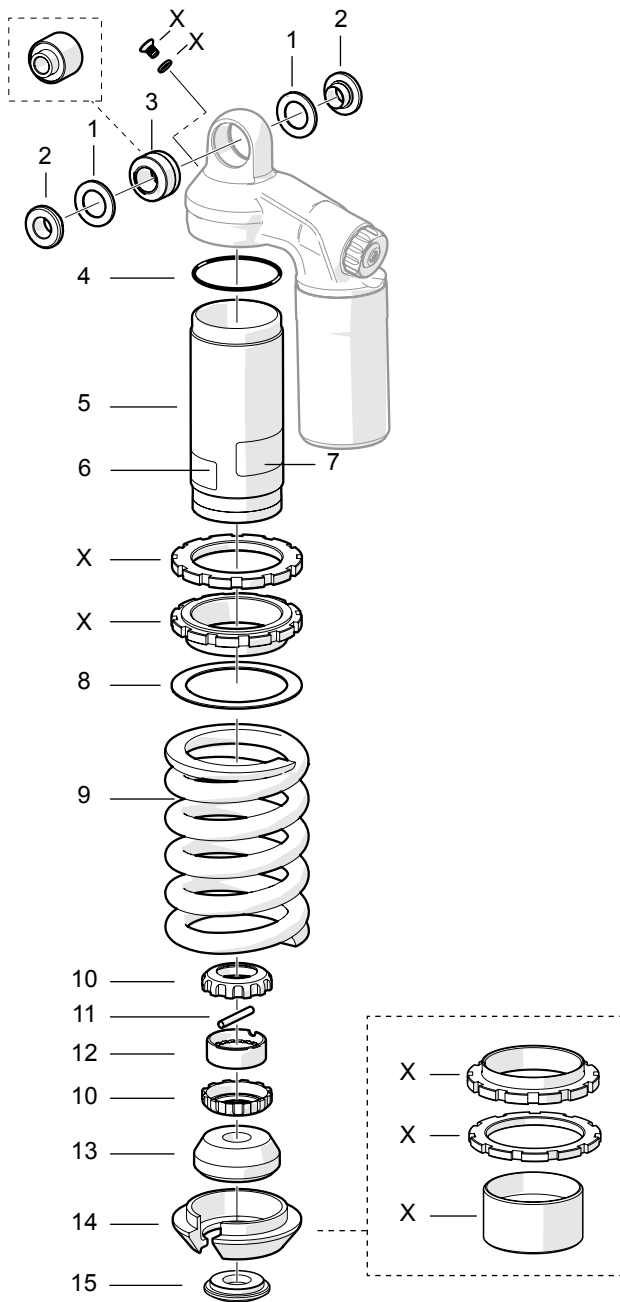

Pos	Part No	Pcs	Description	Notes
1-1	00534-01	2	Seal	
1-2	01218-02	2	Spacer	
1-3	00536-13	1	Ball joint	
1-4	00338-32	1	O-ring	
1-5	01110-04	1	Cyl. tube	
1-6	00196-01	1	Sticker Warning	
1-7	00191-06	1	Sticker ÖHLINS	
1-8	00543-01	1	Washer	
1-9	01096-69	1	Spring	
1-10	01016-01	2	Seal rebound adj.	
1-11	01030-01	1	Pin	
1-12	01128-01	1	Adjuster	
1-13	00563-03	1	Bump rubber	
1-14	00629-01	1	Spring clip	
1-15	01017-01	1	Stop washer	
1-16	01054-02	1	End eye	
1-17	01218-05	2	Spacer	
1-18	00534-01	2	Seal	
1-19	00536-13	1	Ball joint	

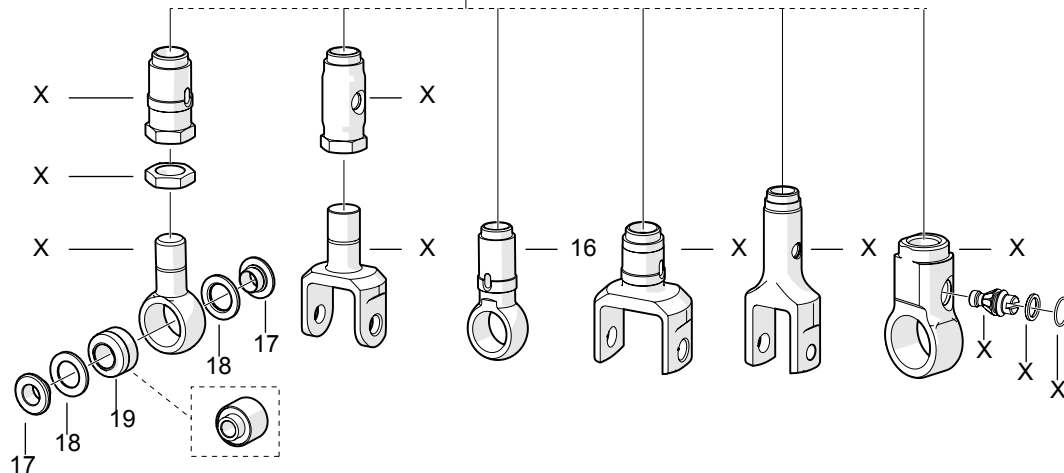

SPL BM 4381

Figure 2 - Shaft assembly

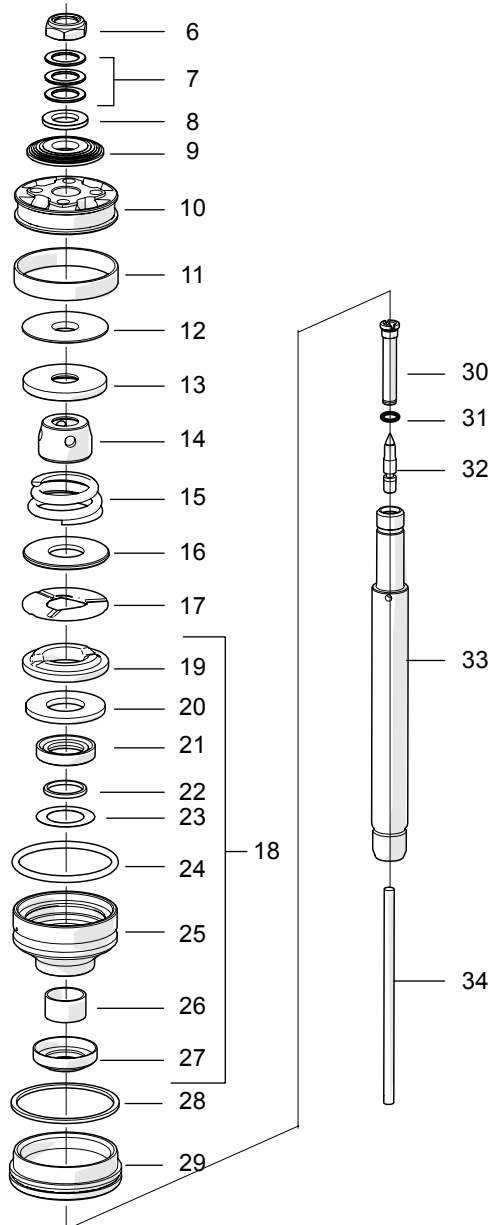
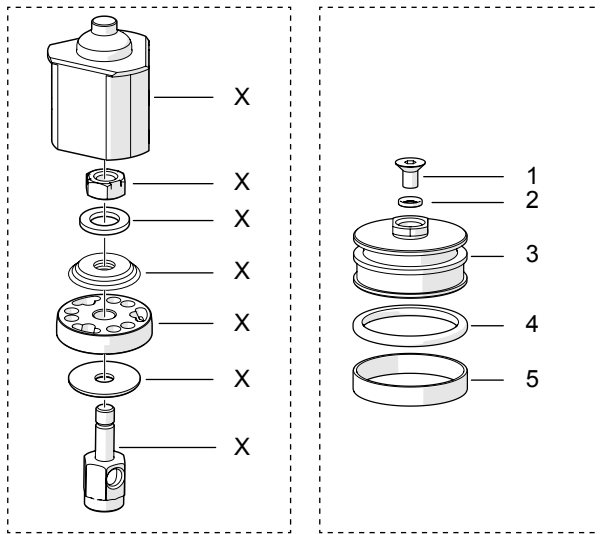

Pos	Part No	Pcs	Description	Notes
2-1	00382-01	1	Screw	
2-2	00338-01	1	O-ring	
2-3	01005-01	1	Piston	
2-4	00338-13	1	O-ring	
2-5	00541-01	1	Piston ring	
2-6	00539-01	1	Lock nut	
2-7	00578-01	3	Washer	
2-8	00519-07	1	Valve stop	
2-9	-	-	Shim stack	See spec. card
2-10	01114-14	1	Piston	
2-11	00541-01	1	Piston ring	
2-12	-	-	Shim stack	See spec. card
2-13	00519-08	1	Valve stop	
2-14	01132-02	1	Tos guide	
2-15	01131-04	1	Top out spring	
2-16	01269-03	1	Spacer	Alum.
2-17	01069-02	2	Spacer	Plastic
2-17	01069-03	1	Spacer	Plastic
2-18	05129-09	1	Seal head assy	
2-19	03067-03	1	Stop rubber	
2-20	04752-03	1	Washer	
2-21	04717-03	1	Seal	
2-22	01032-23	1	Back up ring	
2-23	04729-04	1	Shim	
2-24	00338-46	1	O-ring	
2-25	05122-06	1	Seal head	
2-26	01056-14	1	Bushing	
2-27	01031-02	1	Scraper	
2-28	00575-01	1	Circlip	
2-29	01065-31	1	End cap	
2-30	05621-02	1	Shaft jet	
2-31	00338-14	1	O-ring	
2-32	05655-02	1	Adj. needle	
2-33	05500-19	1	Shaft	
2-34	00566-36	1	Adj. shaft	

SPL BM 4381

Figure 3 - Cylinder head

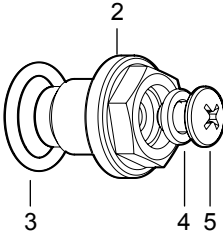
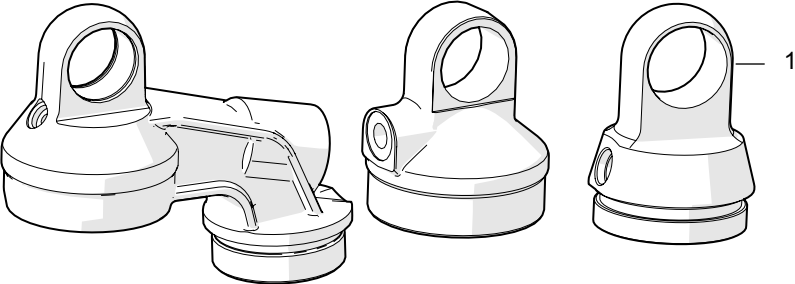

Pos	Part No	Pcs	Description	Notes
3-1	01282-03	1	Cylinder head	
3-2	00603-03		Valve assy	
3-3	00338-07	1	O-ring	
3-4	00338-59	1	O-ring	
3-5	01050-01	1	Screw	

SPL BM 4381

Figure 4 - Hydraulic adjuster type 1

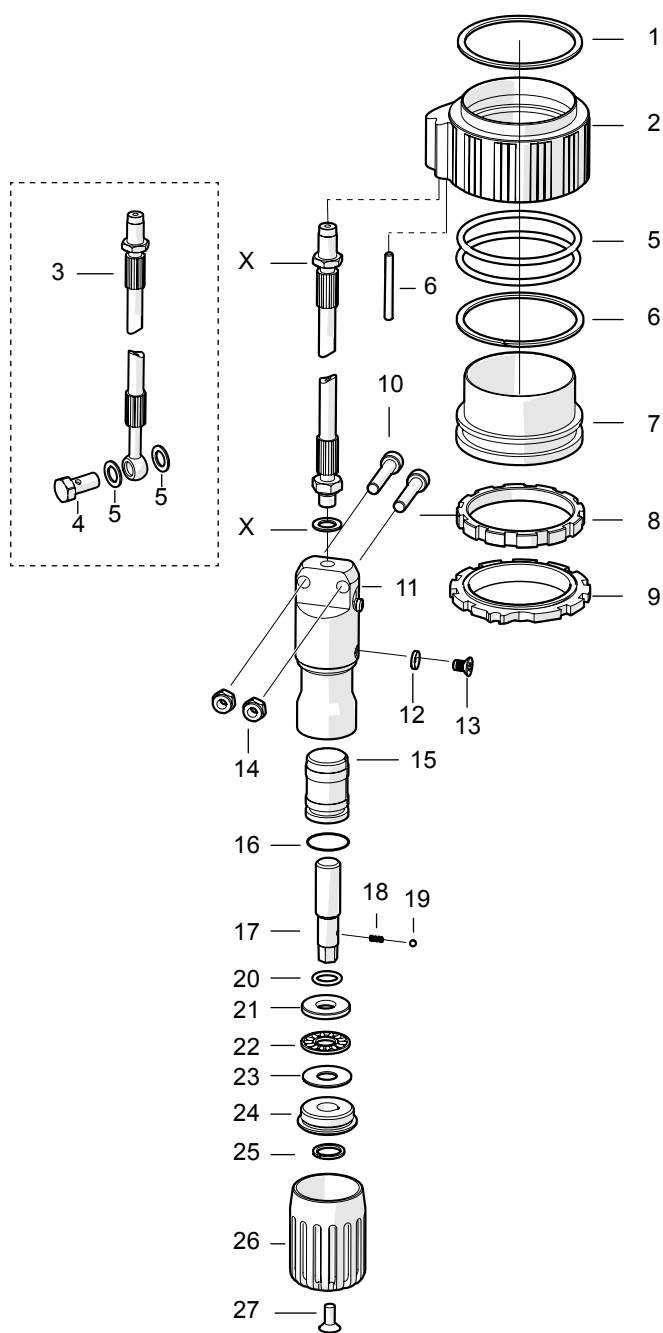

Pos	Part No	Pcs	Description	Notes
4-1	03611-01	1	Support ring	
4-2	03607-01	1	Housing	
4-3	01042-06	1	Hose banjo bolt	
4-4	00831-02	1	Banjo bolt	
4-5	01048-01	2	Seal washer	
4-6	03613-01	1	Pin	
4-5	00338-90	2	O-ring	
4-6	03610-01	1	Support ring	
4-7	03606-01	1	Inner sleeve	
4-8	03609-01	1	Lock nut	
4-9	03608-01	1	Guide nut	
4-10	01046-06	2	Screw	
4-11	03600-02	1	Adj. cylinder	
	00338-79	1	O-ring	Filling screw
	00382-07	1	Screw	Filling screw
4-12	03614-01	1	Seal washer	
4-13	03601-02	1	Guide screw	
	01138-01	2	Spacer	Plastic
	00153-04	2	Washer 6mm	
4-14	00430-02	2	Nut	
4-15	03604-02	1	Piston	
4-16	00338-71	1	O-ring	
4-17	03602-02	1	Adj. screw	
4-18	03083-01	1	Spring	
4-19	00884-03	1	Ball	
4-20	00131-03	1	Circlip	
4-21	03072-02	1	Thrust washer	
4-22	01023-02	1	Needle bearing	
4-23	03073-02	1	Thrust washer	
4-24	03603-01	1	Cover	
4-25	00338-88	1	O-ring	
4-26	03605-01	1	Knob	
4-27	00382-08	1	Screw	
	01082-02	1	Bracket	
	01046-25	1	Screw M8x50	
	00153-01	2	Washer 8mm	
	00430-05	2	Nut M8	

Your Öhlins retailer:

Öhlins Racing AB
Box 722
SE-194 27, Upplands Väsby
Sweden

Phone: +46 (0)8 590 025 00
Fax: +46 (0)8 590 025 80
www.ohlins.com



www.ohlins.com