

# OWNER'S MANUAL YAMAHA YZF-R1

255-008-270-020



## CONTENTS

Page 2	Settings
Page 3	Introduction
Page 4-6	Adjustment
Page 7-8	Fitting the shock/ Service
Page 9-11	Notes

## RECOMMENDED SETTINGS

Shock length	302 (-2+4)mm
Shock stroke	62mm
Spring Rate	95N/mm
Spring Preload	13(-/+5)mm
Comp damping (Black)	14 Clicks Out
Reb damping (Natural)	8 Clicks Out
Bypass Control Valve	8 Clicks Out

K-Tech Suspension Ltd products are manufactured to fit specific brands and models. Under no circumstances should any K-Tech Suspension Ltd products be fitted to an application other than that for which it has been designed, tested and manufactured.

## INTRODUCTION

The DDS Pro Rear Shock Absorber has been designed for use at the highest levels of racing and developed in major championships around the world. Like all other K-Tech products it has been designed and manufactured in the UK using the latest software and highest grade materials and processes available.

The championship winning Direct Damping System provides incredible performance and precise tuning for ultimate chassis control in the most demanding conditions of racing shock absorber. The DDS pro comes with the following specifications listed as standard:

- Hydraulic Preload Adjustment
- Bypass Adjustment
- Compression Adjustment
- Rebound Adjustment
- Length Adjustment

**\*\*\*This product is not designed or intended for highway use.\*\*\***

The procedures in this manual should only be carried out by a qualified motorcycle technician. K-Tech Suspension Ltd will not be liable for any damages caused in any way to/by the product and any injuries sustained if the product is fitted or adjusted by someone who is neither an authorised dealer of K-Tech Suspension Ltd or who does not have the relevant qualifications in motorcycle technology. K-Tech Suspension Ltd will also not be liable if the correct tools are not used throughout the process of fitting and adjustment of a K-Tech suspension Ltd product. Please refer to the manufacturer's workshop manual before attempting these procedures. These procedures will require two people, you will need to remove all relevant bodywork and any other parts that may restrict you from carrying out these tasks.

## ADJUSTMENT

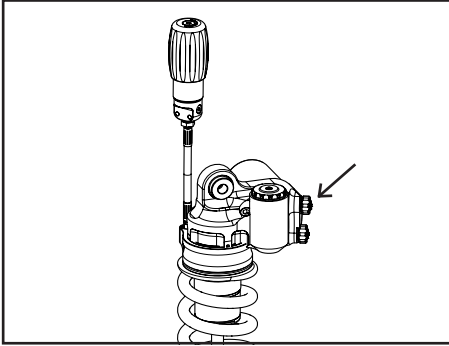

### **Compression damping:-**

Black Adjuster Wheel:- 32 clicks adjustment range. All settings should be made from the fully closed (Clockwise Position).

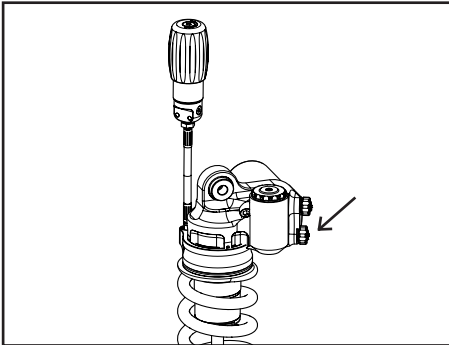

### **Rebound damping:-**

Natural Adjuster Wheel:- 32 clicks adjustment range. All settings should be made from the fully closed (Clockwise Position).

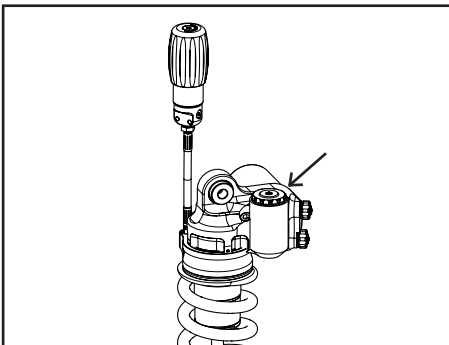

### **Bypass Adjustment Valve:-**

Red Adjuster Wheel:- 16 clicks adjustment range. All settings should be made from the fully closed (Clockwise Position).

## ADJUSTMENT

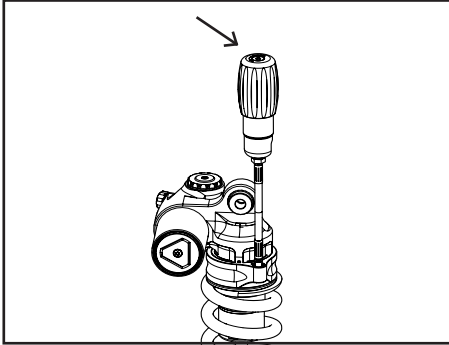

### Spring preload:-

Knob on adjuster body:- 20 clicks adjustment range. All settings should be made from the fully open (Anti clockwise Position).

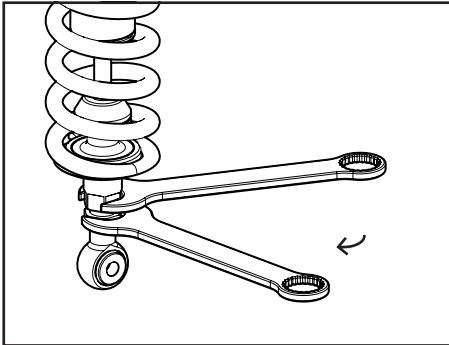

### Shock length:-

To adjust the shock length loose the silver lock nut at the bottom of the shock with a 24mm open ended spanner whilst holding the piston rod joiner assembly (Black 24mm nut) with another spanner.

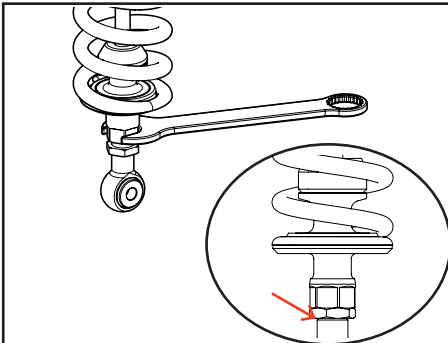

### Shock length:-

Turn the rod using the 24mm spanner to get the desired shock length you require.

**NB** 1 full turn changes the shock length by 1mm.



Do not extended the length of the shock to the point that the safety groove is visible below the locking nut. If you require this length of shock please contact your nearest K-Tech dealer.

## ADJUSTMENT

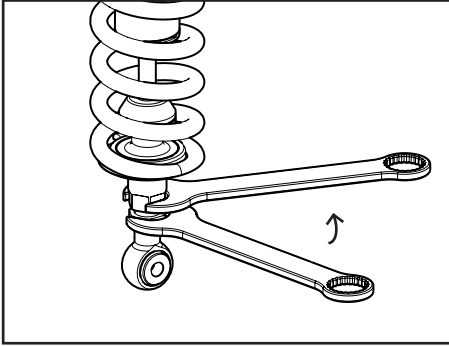

### Shock length:-

When you have changed the shock length re-tighten the silver lock nut to the rod joiner using the two 24mm spanners and torque to 30N/m.

## REPLACING THE SPRING



### Replacing the spring:-

When replacing the spring it is essential to ensure that the preload adjuster is replaced in the **exact** position it was previously in.

**Failure to do so may result in serious damage to the shock absorber and/or bike.**

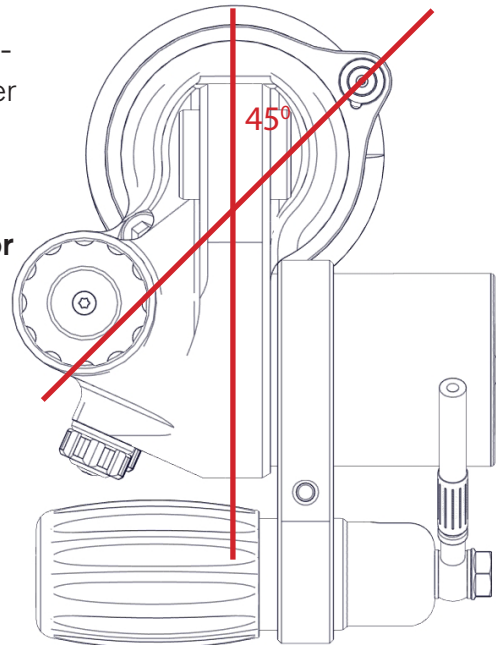

## FITTING THE SHOCK

**This procedure should only be carried out by a qualified motorcycle technician. K-Tech Suspension Ltd will not be liable for any damages caused in any way to/ by the product and any injuries sustained if the product is fitted by someone who is neither an authorised dealer of K-Tech Suspension Ltd or have the relevant qualifications in motorcycle technology. K-Tech Suspension Ltd will also not be liable if the correct tools are not used throughout the process of fitting and adjustment of a K-Tech suspension Ltd product. Please refer to the manufacturer's workshop manual before attempting this procedure. This procedure will require two people, you will need to remove all relevant bodywork and any other parts that may restrict you from carrying out this task.**

Place and secure the motorcycle on an appropriate stand so that the wheel is approximately 5cm off the ground.

Loosen top and bottom mounting bolts using the correct spanners.

With one person holding the rear wheel in a stationary position the second person can remove the top bolt, it may be necessary to slightly move the rear wheel up and down whilst removing the top bolt.

Keeping the rear wheel in a stationary position the second person can now remove the bottom bolt, it will be necessary to hold the shock whilst doing this.

Remove the shock from the bike keeping the rear wheel stationary while doing so.

You are now ready to fit the K-Tech rear shock.

Place the shock into the bike fitting the bottom mounting bolt first, it may be necessary for the second person to slowly move the rear wheel up or down for you to insert the bolt through any linkages.

Now fit the top mounting bolt and torque both top and bottom bolts to the manufacturer's recommendations.

(Continued on next page)

## FITTING THE SHOCK

Remove the left hand side pillion foot rest . Fit the preload adjuster to the bike using the bracket and bolt provided. Tighten the pillion foot rest to the bike using manufacturers torque settings.

**Take a slow test drive to make sure that everything is correct.**

## SERVICE

K-Tech Suspension Ltd recommend that this product is serviced every 20 hours of use. It is very important that this product is serviced by an authorised dealer, as there are special tools required to guarantee correct performance of this product. K-Tech Suspension Ltd cannot be held responsible for any damage caused to/by the product if a service is overdue or was not conducted by an authorised dealer.

**[www.ktechsuspension.com/service-centres-and-partners](http://www.ktechsuspension.com/service-centres-and-partners)**



# DDS PRO SHOCK ABSORBER

## NOTES

# DDS PRO SHOCK ABSORBER

NOTES

Lined writing area consisting of multiple horizontal lines for text entry.





[www.ktechsuspension.com](http://www.ktechsuspension.com)

Contact your local K-Tech dealer for more details at  
[www.ktechsuspension.com/service-centres-and-partners](http://www.ktechsuspension.com/service-centres-and-partners)